

Sinterit LISA X

SLS 3D PRINTER

Translation of the original user manual



Please read the manual before using the product.





In order to ensure safe and efficient operation of Sinterit devices and products, please make sure to follow the instructions and safety guidelines outlined in this manual.

Please be sure to keep this document for future reference.

Table of Contents

1. Glossary	3
2. Safety information	3
2.1 Symbols and visual cues	3
2.2 General safety guidelines and personal protection information	5
2.3 Electric devices – power supply and grounding system	6
2.4 Printers – General usage safety guidelines	7
2.5 Printers – Safety during repair and maintenance	8
2.6 Powders – Safety while working with powder	9
3. General information	10
3.1 Intended use	10
3.2 Operating requirements	10
3.3 Technical specification	11
3.4 Printer description	13
3.5 Printer safety plate	14
4. Unpacking and installing the printer	15
5. First start-up	16
5.1 Powering on and starting the printer	16
5.2 Mounting the laser protective glass	17
5.3 Connecting the printer to the Wi-Fi network	18
5.4 Main menu	19
6. Preparing to print	20
6.1 Choosing the file	20
6.2 Filling the print chamber with powder	21
6.3 Przygotowanie komory druku	21
6.4 Final steps before printing	22
7. During printing	22
8. Removing and cleaning the printout	22
9. Cleaning the printer	24
9.1 Cleaning the print chamber	24
9.2 Cleaning the overflow container	25
10. Printing with PA11	26
11. Powder refreshment	27
11.1 Powder refreshment with PHS	27
11.2 Powder refreshment with Powder Sieve or metal strainer	28
12. Basic maintenance	29
12.1 Cleaning the pyrometer window	30
12.2 Cleaning the laser protective glass	30
12.3 Cleaning the area under the print chamber	32
13. Technical support	32
14. Packing the machine for shipping	32
14.1 Preparing the printer	32
14.2 Packing the printer into the flight case	33
15. Legal notice	33
16. Disclaimer	33
17. Trademarks	34
18. Warranty information	34



1. Glossary

The following terms and forms have been adopted and used in the manual.









- **Print Bed** – a chamber where the powder is sintered and where the 3D model is created.
- **Feed Bed** – a chamber that stores new, unsintered powder. From this chamber, powder is taken layer by layer into the Print Bed.
- **Cake** – contents of the Print Bed after printing is complete. It consists of the printed model and the unbaked powder around the model.
- **IO BOX** – In & Out BOX, a tool designed to pull a cake out of a Print Bed.
- **Flight case** – a special case used to ship the printer.

2. Safety information

2.1 SYMBOLS AND VISUAL CUES

	<p>WARNING! An inevitably dangerous situation which can result in serious injury or even death. Initiation, or omission, of a specific procedure as well as inattention, can cause severe physical injury to the user.</p>
	<p>ATTENTION! Initiation, or omission, of a specific procedure can cause physical damage to the equipment or the user.</p>
	<p>WARNING! Risk of electric shock which can be fatal or cause severe burns. An inevitably dangerous situation, which can result in serious injury or even death, if not mitigated. Before working with any equipment, you should be aware of the dangers associated with the flow of electric current, and become familiar with the standard procedures to prevent accidents.</p>
 	<p>WARNING! Compressed gas! The danger of suffocation! Possibility of unsealing - gas has a suffocating effect on people by displacing oxygen from the air. Too low oxygen concentration in the air can lead to unconsciousness and death, if not mitigated. Inhalation exposure may cause short breath, breathing difficulties, headaches and dizziness, with high concentrations of gas disorders of orientation, nausea, fainting, loss of consciousness, death.</p>
	<p>CAUTION! IR laser radiation. Looking directly into the laser beam can cause blindness and skin burns. The laser emits infrared radiation (infrared, IR), which is invisible to humans. Avoid eye or skin exposure to direct or scattered radiation. Do not stare into the beam or view with optical instruments.</p>
	<p>CAUTION! High temperature – do not touch. Excess heat dissipation can cause burns.</p>
	<p>CAUTION! Beware of moving parts which can crush hands.</p>

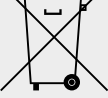

	CAUTION! Beware of sharp edges which can cause body cuts and injury.
	CAUTION! Beware of intense light.
 	WARNING! Risk of fire and explosion! Avoid fire! Powder dust is flammable.
	ATTENTION! Risk of electric shock. A grounding is used in the printer. Follow the instructions in the User manual and the markings on the printer.
	STOP! Action prohibited.
  	ATTENTION! It is necessary to wear adequate protective clothing, eyewear, face mask, and gloves. Mandatory action when working with powder.
	ATTENTION! It is necessary to wear antistatic clothes and shoes. Mandatory action when working with powder.
	IMPORTANT! Information essential to correctly perform a specific task.
	IMPORTANT! You must read the instructions before taking action.
	ATTENTION! Sinterit products and materials may not be suitable for disposal in municipal waste.













2.2 GENERAL SAFETY GUIDELINES AND PERSONAL PROTECTION INFORMATION

	<p>WARNING! Unless these messages are heeded, operator injuries or printer damage could occur.</p>	
	<p>WARNING! The following indications are, by themselves, not enough to fully protect against all the hazards that could arise during printer operation. These will have to be integrated with common sense and the experience of the operator, both of which are crucial factors for preventing accidents. Each section of this manual lists further specific safety warnings for the various operations.</p>	
	<p>WARNING!</p> <ul style="list-style-type: none">• Only trained and qualified personnel should install, replace or service the equipment.• The product should be set up in accordance with these instructions and by trained personnel.• Sinterit products may only be safely used or operated by adults and can pose serious risk to children.	
	<p>ATTENTION! When restoring original working conditions, the appointed personnel should always make sure that at the end of the operating procedure, proper printer operation safety conditions are restored, especially the safety devices and the protective guards.</p>	
	<p>STOP! It is forbidden to climb Sinterit products or equipment, unless and only if they were explicitly designed for that purpose (e.g. stepladders).</p>	
 	<p>ATTENTION! Wear individual protections. Before starting any work with powder, always wear adequate protective clothing, eyewear, face mask, and gloves.</p>	
	<p>ATTENTION! It is recommended to wear antistatic clothing and shoes. The floor in the working area must be antistatic.</p>	











2.3 ELECTRIC DEVICES – POWER SUPPLY AND GROUNDING SYSTEM

	<p>WARNING!</p> <ul style="list-style-type: none">• Before plugging in, make sure the power voltage and frequency are those shown on the machine plate.• When an extension cord is used for the power supply of the product, make sure that the total power consumption of all devices connected to it does not exceed the extension cord's limit. Also, make sure that the total current drawn by connected equipment does not exceed the ampere rating for AC wall outlet.	
	<p>WARNING!</p> <ul style="list-style-type: none">• Use only the power cable supplied with the product.• Do not use power cables from other devices! Using the power cables from other devices or connecting the power cables supplied with the product to other devices may cause fire or electric shock.• The power cable should be placed in such a place that they are not rubbed, cut, pulled or twisted.• Pay special attention to the fact that the power cable is not bent at the points of connection of the printer.• During use, mind the power supply cables and avoid crushing or pulling these.• Periodically check the mains power cable to ensure it is not damaged.• In the event of the cable being replaced, make sure it is protected against water spray and check mechanical strength.• Disconnect the power cable whenever it is planned to shift/transfer the machine.	
	<p>WARNING!</p> <p>In the following situations, unplug the product from the power supply and contact with Sinterit Support:</p> <ul style="list-style-type: none">• the power cable or plug is damaged;• some liquid got into the product;• the product has been dropped or the case has been damaged;• the product does not operate properly or clear changes in efficiency have been observed.	
	<p>STOP!</p> <ul style="list-style-type: none">• Never touch electric wires, switches, buttons, etc. with wet hands.• Never pull the machine by means of the power cable. When connecting/ disconnecting the plug to/from the power socket always hold the cover, not the cable.• In the event of the cable being damaged, the machine must not be used.• Never disassemble, modify or repair the power cable, plug, devices inside the printer, except as described in the product manual.• Do not place objects on the Power cable.• Do not place Power cable in a path where people will have to walk or run.	
	<p>ATTENTION!</p> <p>It is recommended to use UPS units that, in the case of a momentary power failure, will allow the printing process to finalise.</p>	
	<p>ATTENTION!</p> <p>Industrial equipment, such as provided by Sinterit, must always be connected to a grounded outlet to prevent electric shock in the event of a fault.</p>	









2.4 PRINTERS – GENERAL USAGE SAFETY GUIDELINES

	<p>WARNING! Before printing, always make sure the printer is free of all external materials such as debris, oil, equipment and other objects that could affect the operation and cause injury to people.</p>	
	<p>ATTENTION!</p> <ul style="list-style-type: none">• During printing, if there is a lot of smoke, irritating smell or other alarming circumstances take place, press the Safety button. It will immediately cut off the power from the printer.• However, remember that it is impossible to open the printer (e.g.: by lifting the lid) until the temperature inside will not drop below 50°C and the UNLOCK LID option becomes available.	
	<p>WARNING! <u>INERT GAS INSTALLATION</u> Possibility of unsealing - gas has a suffocating effect on people by displacing oxygen from the air. Too low oxygen concentration in the air can lead to unconsciousness and death. Inhalation exposure may cause short breath, breathing difficulties, headaches and dizziness, with high concentrations of gas disorders of orientation, nausea, fainting, loss of consciousness, and death.</p> <ul style="list-style-type: none">• Store in a well-ventilated place.• Do not inhale the gas.• Nitrogen is an inert gas, a natural component of atmospheric air. It is not harmful in the aquatic environment or soil, its adverse effect is limited to the displacement of oxygen.• The built-in oxygen level sensor is not a certified device and the signal cannot be treated as the only warning. Keep the Lisa X printer and the inert gas bottle in well-ventilated rooms.• If you hear an alert, open the windows/ventilate the room and leave the room.• If you feel any suspicious symptoms, immediately leave the room and go outside/to a well-ventilated room.	 
	<p>ATTENTION! <u>LASER PROTECTIVE GLASS</u></p> <ul style="list-style-type: none">• The cleaning process of the laser protective glass should be carried out outside of the printer.• Do not clean the laser protective glass under running water.• Only use products with ethyl alcohol. We recommend alcohol pads (available in the Service Kit).	
	<p>ATTENTION! While the printer is working do not touch any other elements besides: the LCD screen, the emergency stop pushbutton (E-STOP), the USB port and the power switch.</p>	











2.5 PRINTERS – SAFETY DURING REPAIR AND MAINTENANCE

	<p>WARNING!</p> <ul style="list-style-type: none">• Only trained personnel should carry out repairs.• Read the user manual carefully before using the printer or doing any maintenance jobs.• During cleaning operations, maintenance jobs or when changing parts, the power switch must be off and the machine must be unplugged by removing the power cable from the socket.• During maintenance jobs, affix a notice to the appliance indicating „MACHINE BEING SERVICED, DO NOT START“.• Do not adjust controls that are not described in the manual.	
	<p>WARNING!</p> <ul style="list-style-type: none">• Structural damage and improper alterations or repairs could change the protection capacity of the printer and therefore void the warranty.• Any alterations to the appliance can only be made by Sinterit Support.• In the event of Customers fitting a tool to the machine not supplied by Sinterit, make sure the safety conditions required by Machine Directive 2006/42/CE are complied with and in any event, Sinterit is unable to accept liability for any problems arising from the use of such a tool.	
	<p>STOP!</p> <p>Avoid using flammable or toxic solvents for cleaning and maintenance such as petrol, benzene, ether and alcohol for cleaning.</p>	 

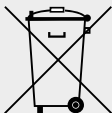

2.6 POWDERS – SAFETY WHILE WORKING WITH POWDER

	<p>WARNING!</p> <ul style="list-style-type: none">• When working with the polyamide powder or other designated printer powder for the Sinterit Lisa X printer, always wear personal protection dedicated to this device (protective glasses, protective gloves, protective dust mask).• When working with a powder, avoid inhalation or swallowing and contact with skin and eyes.	 
	<p>ATTENTION!</p> <ul style="list-style-type: none">• Polyamide powder should be stored in tightly closed containers (e.g sinterit metal container), in a room at room temperature and low humidity.• The powder should be stored out of reach of children and pets.• If the device is not used for a long time, the powder should be removed from the printer and stored in a sealed package (e.g Sinterit metal container).	
	<p>ATTENTION!</p> <p>When printing the smell of melting material may be emitted in intensities which do not affect the health of users. However, in the case of long-term operation of the printer in a poorly ventilated room, the smell may become unpleasant and irritating. Adequate ventilation is recommended in order to create the best printing conditions.</p>	
	<p>STOP!</p> <p>Do not attempt to burn/melt polyamide powder. The resulting sparks and hot mass can cause severe burns. Keep the powder material away from fire.</p>	 
	<p>STOP!</p> <p>Do not dispose of in municipal waste! The used powder material should be stored in sealed containers and disposed of in accordance with local policy of waste plastic material.</p>	



3. General information

3.1 INTENDED USE

Sinterit Lisa X is a compact 3D printer, making use of the selective laser sintering (SLS) technology in additive manufacturing (AM) processes. In its operation, it uses powdered polymers as the source material. The device enables professional and quick manufacturing of physical 3D objects from their digital models. Improper use of the machine may be dangerous for the operator and damage the machine.

3.2 OPERATING REQUIREMENTS

It is strongly recommended that the environment, where the machine will be installed and operated, match the criteria listed below:

Condition	Wartość / Opis
Air humidity	40-59 [%]
Storage conditions	0-40 [°C] (32-104 [°F])
Suggested air conditioning setting while the printer is in use	16-25 [°C] (61-77 [°F])
Optimal ambient temperature while the printer is in use	22 [°C] (72 [°F])
Ventilation	Min. 4 full air changes per hour
Minimum surface area of the working room	3.4 [m ²] / 36.5 [ft ²] with vacuum 5.4 [m ²] / 58.1 [ft ²] without vacuum
Minimum doorway width	0.9 [m] / 2'11.5"
Minimum room height	Min 2.4 [m]

It is additionally advised that a hygrometer (air humidity sensor) be installed in the immediate vicinity of the printer, in order to enable monitoring and control.



IMPORTANT!

The room where the printer is operated needs to be well-ventilated, with stable air temperature and humidity; kept relatively clean, ergonomic and arranged with an efficient workflow in mind.



ATTENTION!

The printer should not be placed directly next to an AC power source or air vents.



3.3 TECHNICAL SPECIFICATION

GENERAL INFORMATION	
Technology	SLS - selective laser sintering
Laser type	IR Fiber Coupled Diode Laser, 30W; $\lambda = 976 \pm 3$ [nm] rated to > 30,000 hrs
Laser scanner type	Galvo
Dimensions	650x610x1200 [mm] (25.6x24.0x47.2 [in])
Weight	145 [kg] (319.7 [lbs])
PRINT VOLUME	
Max size of print diagonally¹	398 [mm] (15.7 [in])
Max print volume	TPU based / Flexible materials: 130x180x340 [mm] (5.1x7.1x13.3 [in]) PA / PP: 130x180x330 [mm] (5.1x6.7x13.3 [in])
PRINTER PARAMETERS	
Size of Print Bed	150 x 200 x 350 [mm] (5.9 x 7.9 x 13.8 [in])
Layer height Z (min-max)	0.075 - 0.175 [mm] (0.003 - 0.006 [in])
Build Speed	up to 14 [mm/h] (0.55 [in/h])
PRINT FEATURES	
Min. wall thickness	od 0.5 [mm] (0.020 [in])
Hole diameter	od 0.5 [mm] (0.020 [in])
Moving part clearance	od 0.2 [mm] (0.008 [in])
ADDITIONAL PRINTER FEATURES	
Inert gas control system	built-in
Average inert gas consumption	0.48 [m ³ /h] = 8 [l/min.]
SOFTWARE	
Software²	Sinterit Studio
Supported file types	STL, 3MF, OBJ, 3DS, FBX, DAE
Output file types	*.scode, *.sspf, *.sspzf
OS compatibility	Microsoft Windows 10 or higher



COMMUNICATION	
LCD screen	9" interactive touchscreen
On-board camera	Built-in
Connectivity	WiFi / Ethernet / USB
HEATING SYSTEM	
Independent	4 modifiable zones: print chamber , print surface, cylinder and piston - 16 independent heating elements
Max temperature in the chamber	210 [°C] / 410 [°F]
POWER	
Operating voltage	230 [V] AC, 50/60 [Hz], 8 [A] or 100-120 [V] AC, 50/60 [Hz], 15 [A]
Average power consumption	0.85 [kW]
Maximum power consumption	1.65 [kW]



3.4 PRINTER DESCRIPTION

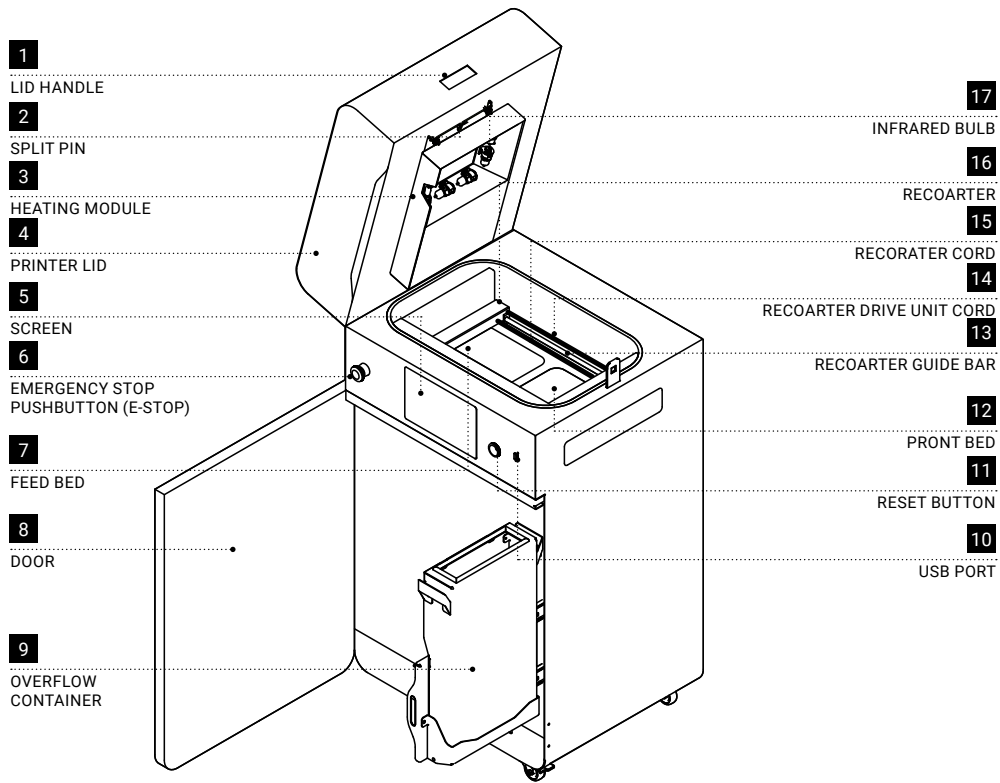

Fig. 3.1 Front view of the printer, heating module and overflow container.

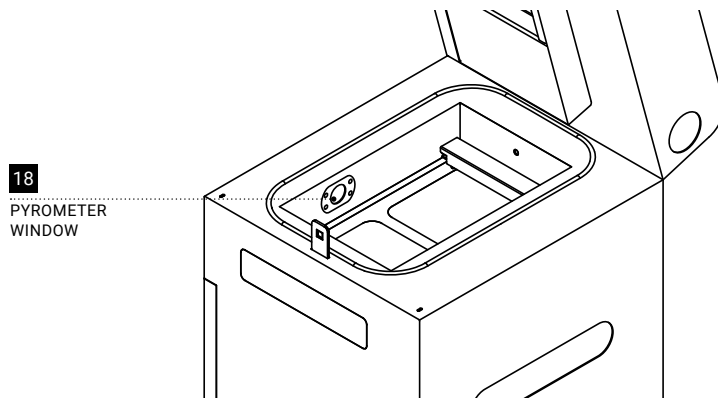

Fig. 3.2 View of the print chamber.

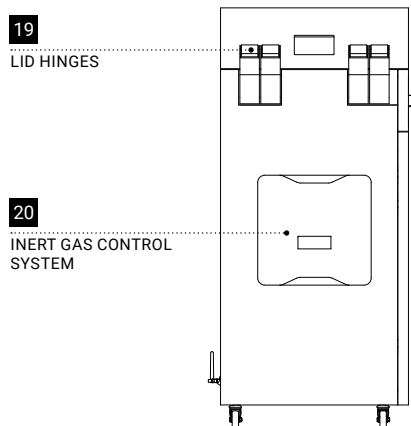

Fig. 3.3 View of the left side of the printer.

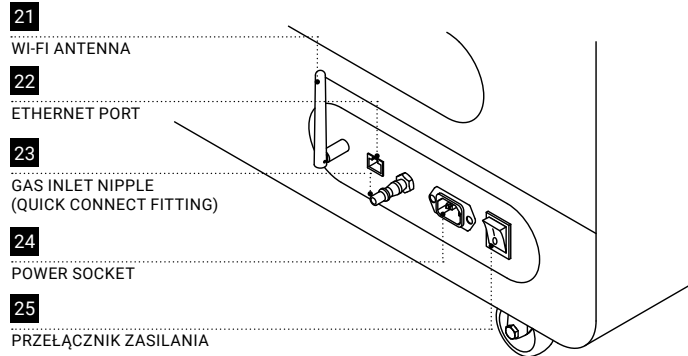

Fig. 3.4 View of the back of the printer.

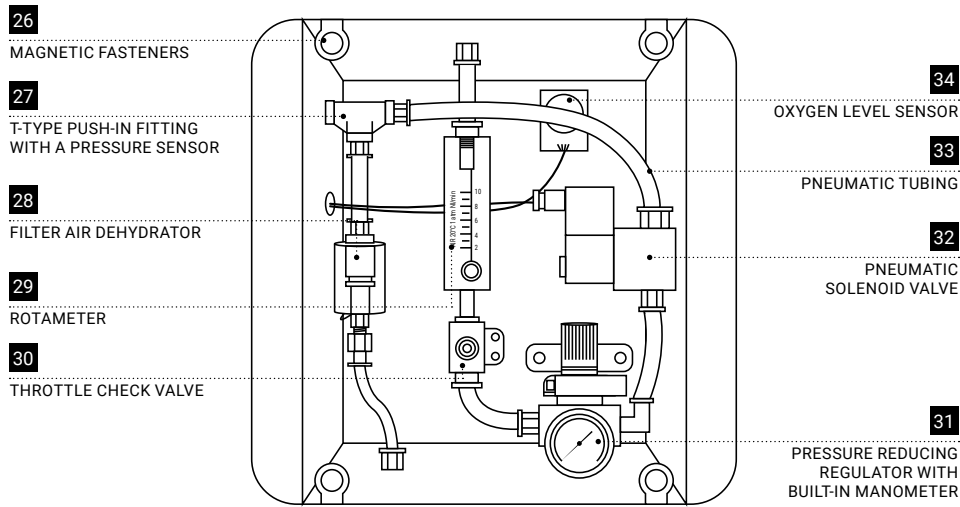





Fig. 3.5 View of the inert gas control system.

3.5 PRINTER SAFETY PLATE

DO NOT REMOVE THIS LABEL!			
Manufacturer:  SINTERIT Sinterit sp. z o.o. ul. Nad Drwiną 10 bud. B3, 30-741 Kraków, Poland www.sinterit.com support@sinterit.com		Name: Lisa X Serial number: Manufactured: Made in: EU, POLAND	
IEC Protection Class:	Machine type:	SELECTIVE LASER SINTERING 3D PRINTER	
 Class 1	Dimensions:	650 x 610 x 1200 [mm]	25.6 x 24.0 x 47.2 [in]
	Total weight:	145 [kg]	319.0 [lbs]
IP Code:	IP30	Power consumption: 190-240 [V] AC, 50-60 [Hz], 1650 [W]	
 	AC current	8 [A] / 230 [V] AC	
	Number of phases	1	
	Short-circuit current rating	6 [kA]	
WARNING! Read and understand operator's manual and all other safety instructions before using this machine. Failure to follow operating instructions could result in serious injury.			



4. Unpacking and installing the printer



IMPORTANT!

Upewnij się, że drukarka nie została uszkodzona podczas transportu. W przypadku jakichkolwiek wątpliwości, skontaktuj się z działem support: SUPPORT@sinterit.com

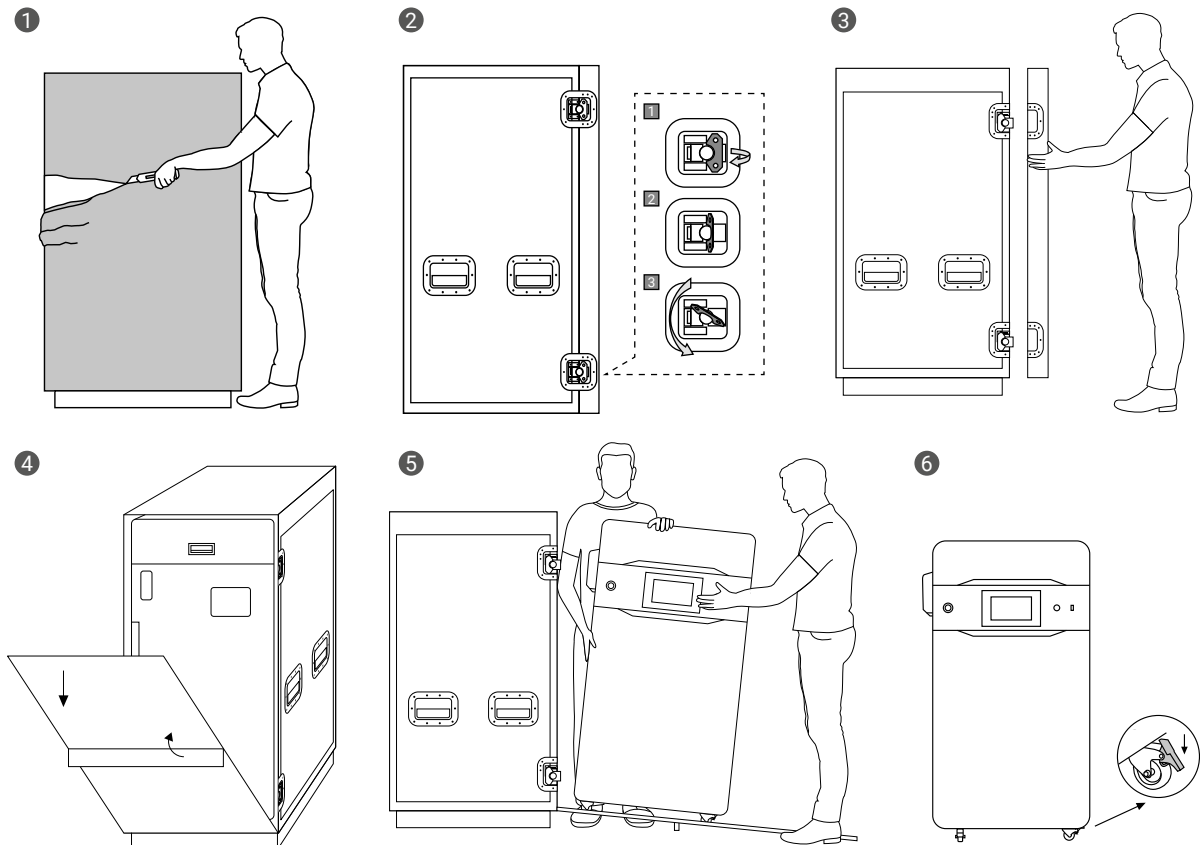

1. Cut through the protective foil covering the flight case.
2. Unlock the latches on the case door (4 pcs.). Lift the lock handle up to a perpendicular position, then turn it clockwise.
3. Take the flight case cover off. Remove the power cable attached to the flight case cover.
4. Lift the gangway support and lower the gangway.
5. Slide the printer out of the flight case. This step requires the help of another person.
6. Place the printer in its desired location, then lock the wheels (there are 2 locks).



5. First start-up



IMPORTANT!

When the printer is turned on for the first time, a short introduction will be shown on the screen, allowing you to familiarize yourself with the machine operation.



IMPORTANT!

The accessories in the Dedicated Powder Tools recommended when working with the printer are not part of the printer you purchased. For more information, visit our website: www.sinterit.com.

5.1 POWERING ON AND STARTING THE PRINTER

1. Connect the printer to power (fig. 5.1).

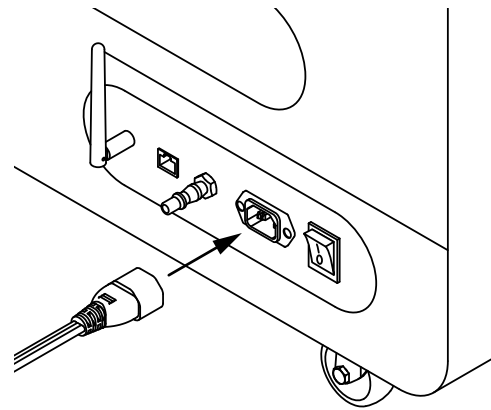

Fig. 5.1 Connecting the power cable to the power socket.



ATTENTION!

Lisa X is supplied with 230 [V]. If you wish to connect the machine to 110 [V], use the voltage converter included with the printer.

2. Flip the power button on the back of the printer to the I position.
3. Make sure that the E-STOP button is released. If not, twist it clockwise up to the stop and release (fig. 5.2).

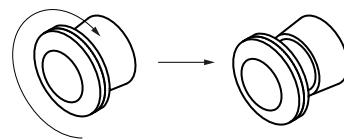

Fig. 5.2 Releasing E-STOP button.

4. After a few seconds, a short tutorial will appear on the screen. The following steps will be explained in detail later in the tutorial.



5.2 MOUNTING THE LASER PROTECTIVE GLASS



ATTENTION!

Beware of sharp edges. Wear the protective gloves, in order to prevent cutting yourself on the sharp edge of the laser module.

1. Choose **UNLOCK LID** on the printer screen.
2. Push on the lid and pull it up using the lid handle.
3. Remove the box with the laser protective glass and other accessories.



IMPORTANT!

After 10 seconds the electrolock will reactivate and it will no longer be possible to lift the lid. If you still want to open the printer, slide the **UNLOCK LID** button again on the printer screen.

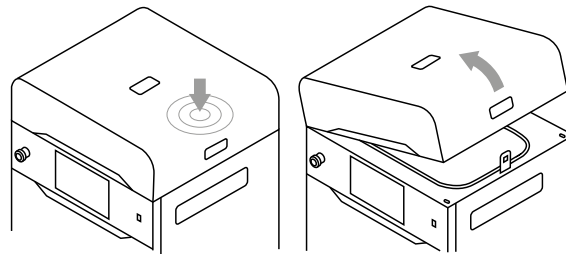

Fig. 5.3 Lifting the printer lid.

4. Remove the split pin from the heating module.
5. Lower the heating module.
6. Remove the protective plastic cover from the laser module. Put it in the flight case for safekeeping.
7. Take the laser protective glass out of the box. Then put the box in the flight case for safekeeping.
8. Delicately wipe the glass on both sides with a cotton cloth soaked in 2% salicylic spirit (ethanol solution) or another ethanol-based cleaning solution. You may also use cleaning wipes provided in Dedicated Powder Tools.



IMPORTANT!

Do not use isopropyl alcohol to clean the laser protective glass.

9. Wipe the glass again on both sides with a dry cotton cloth.
10. Slide the metal tabs of the laser protective glass into the mounting brackets below the laser module.
11. Lock the laser protective glass in place by mounting and tightening the two quick release nuts.
12. Lift the heating module.
13. Reinsert the heating module safety pin.

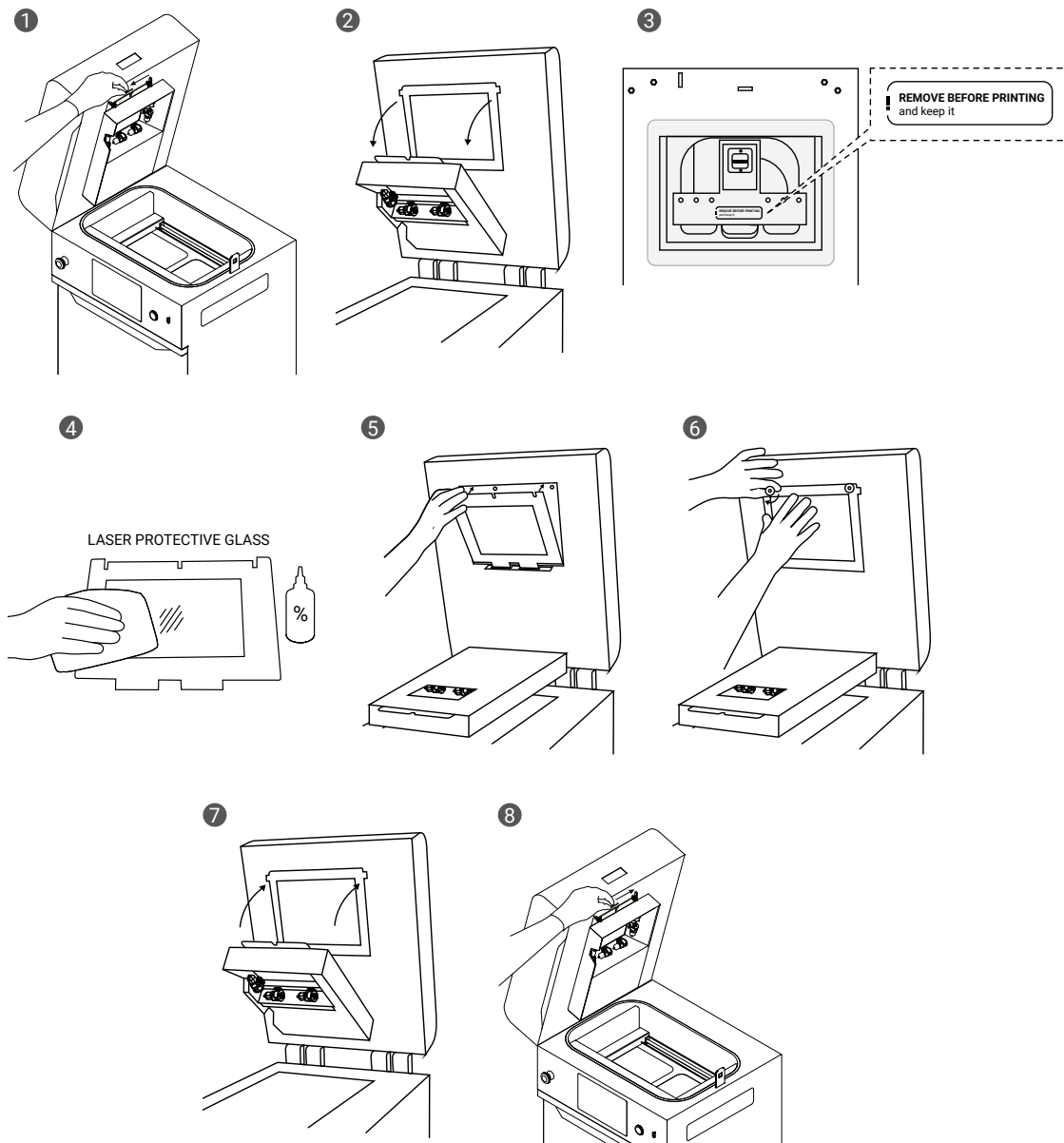

Fig. 5.4 Mounting the laser protective glass.

5.3 CONNECTING THE PRINTER TO THE WI-FI NETWORK

1. From the main menu choose **SETTINGS** ⚙️, or press 📶 top left corner.
2. Choose **WI-FI** on the printer screen.
3. Choose the name of the network, to which you want to connect.
4. Press **CONNECT** by the chosen network name.
5. Input the password and press ✓.
6. Once the connection has succeeded, the network will be marked with a ✓.



IMPORTANT!

In case you want to change the connected network, press **FORGET** and repeat the steps above.



5.4 MAIN MENU

The main menu consists of four positions: **PRINTING**, **MAINTENANCE**, **SETTINGS** and **CAMERA VIEW**.

PRINTING – starts a new printing process

- **ADD NEW PRINT JOB** – with this you can start a new print job.

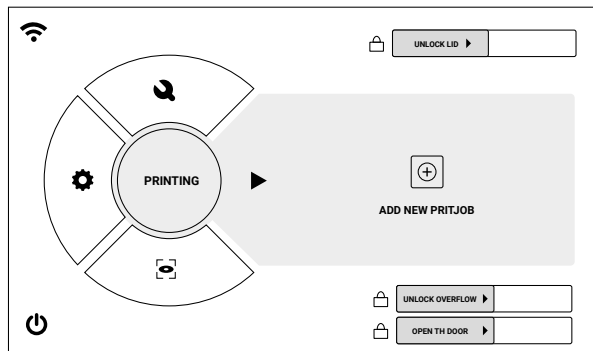

Fig. 5.5 The **START NEW PRINT** screen.

MAINTENANCE – options for servicing the printer.

- **CLEAN THE PRINTER** – choose this option if you want to clean the printer, e.g. if this step was skipped after the printout was removed,
- **REMOVE PRINTOUT** – choose this option to remove a printout still in the printer,
- **COMPONENT MAINTENANCE** – choose this option to check the status of printer components (e.g., how much time is left to change the recoater cord),
- **PRINT JOB HISTORY** – choose this option lets you view the history of completed print jobs,
- **MOTORS** – this option lets you change the position of the overflow, Print and Feed Beds and to initiate homing.

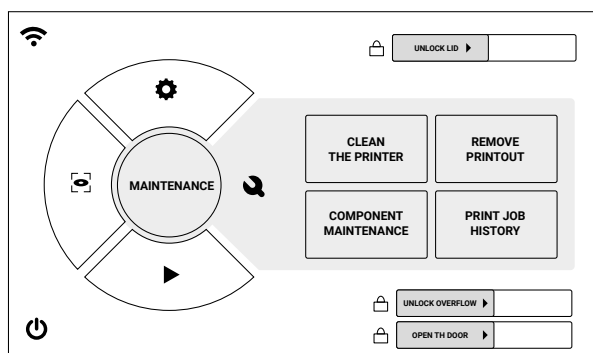

Fig. 5.6 The **MAINTENANCE** screen.

SETTINGS – printer settings

- **CONNECT WITH SINTERIT STUDIO** choose this option to connect with the dedicated printer software on a computer,
- **WI-FI** – choose this option to connect to a Wi-Fi network,
- **PRINTER INFO** – this option lets you view basic technical information of the printer: current software version, IP address on the network and the last used printing material
- **MORE OPTIONS** – choose this option in order to update the printer firmware or to restore factory settings.

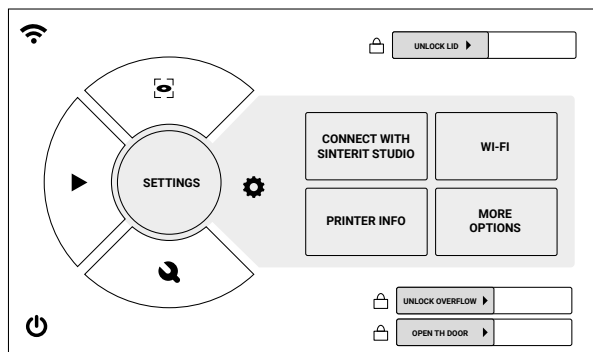

Fig. 5.7 The **SETTINGS** screen.

CAMERA VIEW – view from the built-in camera

- Choose this option to view the inside of the print chamber, including while printing, as seen by the built-in camera.

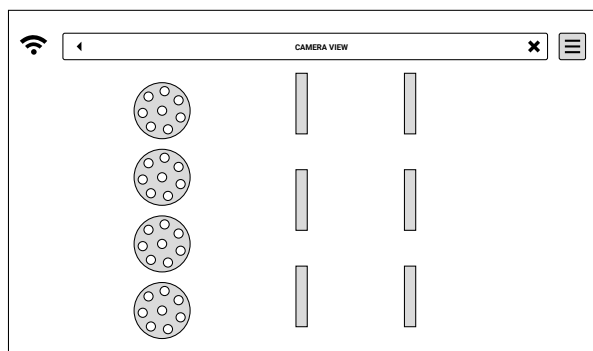

Fig. 5.8 The **CAMERA VIEW** screen.



6. Preparing to print



ATTENTION!

While preparing the printer for use, it is necessary to read and acknowledge any messages on the screen. Disregarding or skipping any crucial steps of the process can negatively impact the quality of printouts or damage the printer.



IMPORTANT!

While preparing the printer for use, make sure that the overflow container has been emptied.

6.1 CHOOSING THE FILE

1. In order to start printing, from the main menu choose **NEW PRINT** ▶ and press ⊕ **ADD NEW PRINT JOB**.
2. Choose the file from the list – **NEW PRINT JOB** or repeat a **RECENT PRINT JOB**. The screen may display 4 print status messages:

Print status	Description
OK	File added successfully.
Printer warning	The file was prepared for another printer. Printing is still possible but the quality cannot be guaranteed.
Open parameters error	Plik wykorzystuje parametry otwarte, ale drukarka nie posiada odpowiedniego pakietu oprogramowania. The printing process cannot continue. Please contact technical support for further guidance: SUPPORT@sinterit.com
Material error	The file uses a different printing material than the one last used with the printer. The printing cannot continue until the material is changed.

3. The following screen displays some basic information about the processed file (**PRINT JOB**) as well as the current status of the printer (**PRINTER STATUS**). If at this point you want to choose another file to print, choose **CHANGE PRINT JOB**. The **PRINTER STATUS** tab shows time remaining until necessary maintenance of select printer components. Press the ... on the right by the element name for more information. A detailed description of the maintenance processes has been provided in section 12 *Basic maintenance*.



IMPORTANT!

If any part of the printer requires maintenance or replacement, a corresponding message will appear on the screen.



IMPORTANT!

It is always possible to go back to the main menu on the screen without interrupting the printing process.

4. Press **START NEW PRINT** button do continue.



6.2 FILLING THE PRINT CHAMBER WITH POWDER

1. Slide the **UNLOCK LID** button to release the electrolock and allow the print chamber to be opened



IMPORTANT!

After 10 seconds the electrolock will reactivate and it will no longer be possible to lift the lid. If you still want to open the printer, slide the **UNLOCK LID** button again on the printer screen

2. Push on the lid and pull it up using the lid handle (fig. 6.1).

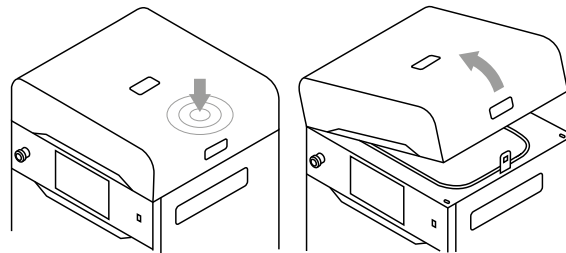

Fig. 6.1 Lifting the printer lid.

3. Make sure the print chamber is free of any unwanted items that may interfere with the operation of the recoater.
4. Press **AUTO HOME** to begin homing the Feed Bed and Print Bed positions.
5. Once the homing process is finished, fill the Feed Bed up with the desired powder. You may use the powder funnel provided in the Dedicated Powder Tools. Afterwards press **DONE**.



IMPORTANT!

The information which powder to use has been displayed on the printer screen as well as in the Sinterit Studio software end report.

6. Compress the powder using the metal spatula provided in the Dedicated Powder Tools. This will release air accumulated in the Feed Bed as you pour in the powder. Afterwards press **DONE**.
7. Remove any powder spilled directly under the guide bars. You may use the brushes and spatulas provided in the Dedicated Powder Tools. Afterwards press **DONE**.
8. Choose **START LEVELING** to begin leveling the powder surface.
9. You should see a smooth powder surface in the print chamber. If you are satisfied with the achieved powder surface press **STOP LEVELING**.
10. Press **DONE**.

6.3 PRZYGOTOWANIE KOMORY DRUKU

11. Delicately wipe the pyrometer window with a cotton cloth soaked in 2% salicylic spirit (ethanol solution) or another ethanol-based cleaning solution. You may also use cleaning wipes provided in the Dedicated Powder Tools.
12. Wipe the pyrometer window again with a dry cotton cloth, in order to remove any alcohol residue. Afterwards press **DONE**.
13. Wipe the recoater guide bar with a cotton cloth soaked in 2% salicylic spirit (ethanol solution) or another ethanol-based cleaning solution. You may also use cleaning wipes provided in the Dedicated Powder Tools.
14. Wipe the recoater guide bar again with a dry cotton cloth, in order to remove any alcohol residue. Afterwards press **DONE**.
15. Apply silicone oil (available in the Dedicated Powder Tools) to both guide bars. A few drops along the whole length is enough. Afterwards press **DONE**.
16. Make sure the print chamber is free of any unwanted items (i.e. spatulas), then close the lid. Afterwards press **DONE**.



6.4 FINAL STEPS BEFORE PRINTING

1. Press the **RESET** button on the printer itself, in order to activate the safety mechanism.
2. The preparation is finished. The screen shows basic information about the printing process.
3. You can choose **CAMERA VIEW** in the bottom left corner of the screen, to see into the print chamber via the built-in camera. This way you can make sure no tools have been left inside.
4. Choose **START PRINT** to begin printing.
5. Before the printing begins, the printer will run a self-check of its key components.

7. During printing

1. While the printing is in progress, the screen will display basic information about the printing process. You can choose **CAMERA VIEW** to see into the print chamber via the built-in camera.
2. In case you want to abort the process, choose **ABORT PRINTING**.

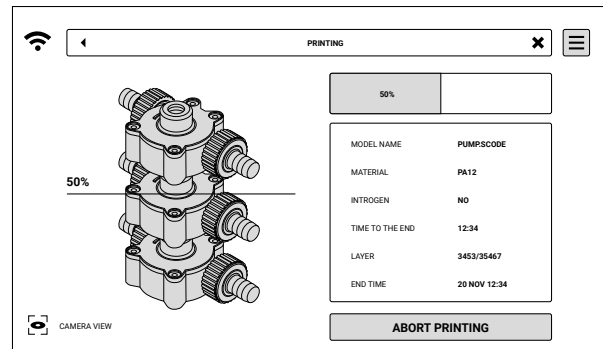

Fig. 7.1 The **PRINTING** screen.



ATTENTION!

While the printing is in progress, in case you observe smoke, an irritating smell or any other dangerous signs, it is important to quickly press the Emergency stop pushbutton (**E-STOP**). This will immediately cut off power to the printer. It is important to note that the printer will not open while the temperature inside the print chamber stays above 50 [°C].



WARNING!

While the printing is in progress, the printer's case might get dangerously hot. Do not press any elements beside the screen, the emergency switch, the **RESET** button, the USB port and the power switch on the back.

8. Removing and cleaning the printout

1. Once the screen displays a message saying **FINISHED** (fig. 8.1) the printing process is over. Choose **REMOVE PRINTOUT** to retrieve it from the print chamber.
2. After the print is finished, the screen may show a message saying **MAINTENANCE TIME**. It contains information on required maintenance to certain components of the printer in the near future. For more information, see Chapter 12. *Basic maintenance*. If the message hasn't appeared, it means that no components require any maintenance. Press **GOT IT**.

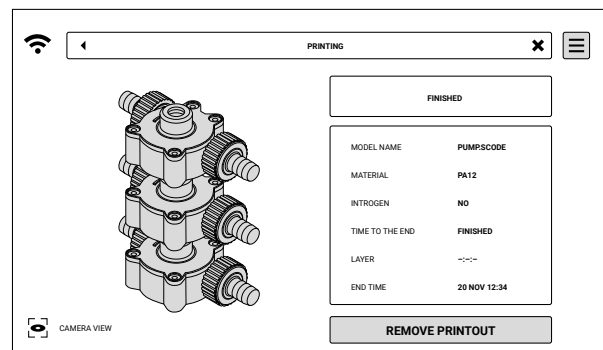

Fig. 8.1 The screen informs the user that the printing is finished.



ATTENTION!

Remember to regularly perform printer maintenance as instructed. Exceeding the designed lifetime of printer components may negatively impact printouts quality and cause damage to the device.

3. Press **UNLOCK LID** on the screen to release the electrolock and allow the printer to be opened.



ATTENTION!

After 10 seconds the lock will reactivate and it will no longer be possible to lift the lid. If you still want to open the printer lid, press the **UNLOCK LID** button again on the screen.

4. Push on the lid and pull it up using the handle (fig. 8.2).

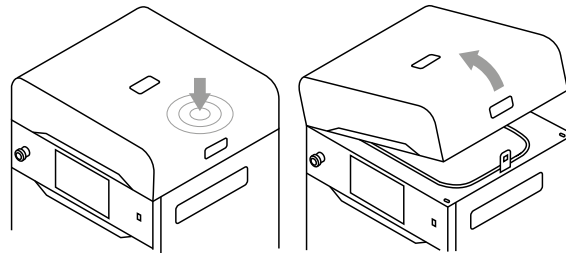

Fig. 8.2 Lifting the printer lid.

5. Place the folded IO BOX inside the print chamber. Make sure its elements are arranged like in the figure 8.3.

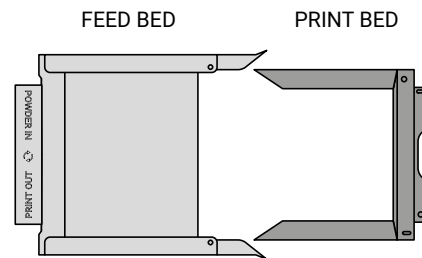

Fig. 8.3 The proper arrangement of the IO BOX, allowing the user to remove the finished printout.

6. Choose **REMOVE PRINTOUT** and wait until the content of the Print Bed (the cake) is ejected.
7. Join the IO BOX elements together like in the figure 8.4.

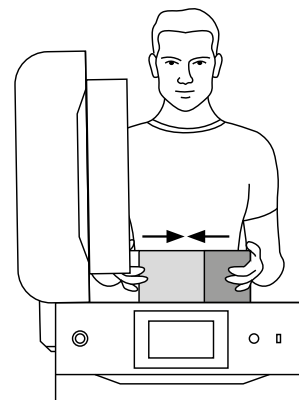

Fig. 8.4 Closing the IO BOX.

8. Carry the IO BOX and its content onto the foldable tray from Dedicated Powder Tools ① or onto the PHS worktop ② (fig. 8.5).

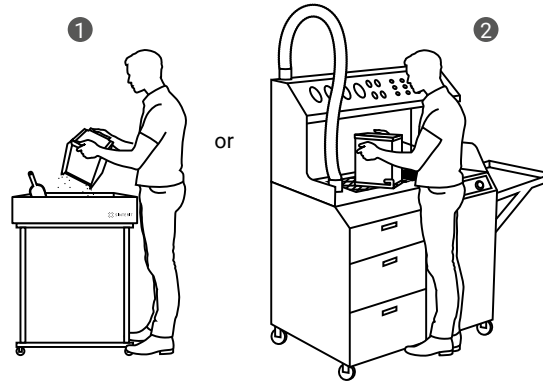

Fig. 8.5 Transferring the IO BOX onto the foldable tray **1** or onto the PHS worktop **2** in order to clean the printout.

9. Choose **DONE** on the printer screen.
10. Clean the printout from unsintered powder. You may use the brushes and the probe provided in Dedicated Powder Tools.

9. Cleaning the printer



IMPORTANT!

- Cleaning the printer is recommended immediately after each printing.
- The SLS powders are hygroscopic (draw moisture out from the air). The print chamber and the overflow container are not 100% airtight. Leaving the powder inside of the printer may cause it to become wet and lose its intended properties.

9.1 CLEANING THE PRINT CHAMBER

1. Press **YES, I DO**, to start cleaning the printer. If you instead intend to do it later and finish for now, choose **NO, NEXT TIME**.
2. Make sure that no tools remain inside the print chamber. Afterwards press **AUTO HOME** to begin homing the Feed Bed and Print Bed positions.
3. For cleaning the printer Sinterit recommends dedicated solutions: the PHS (Powder Handling Station) with a specialized vacuum (ATEX/INTERTEK Vacuum Cleaner) or the vacuum by itself (fig. 9.1).

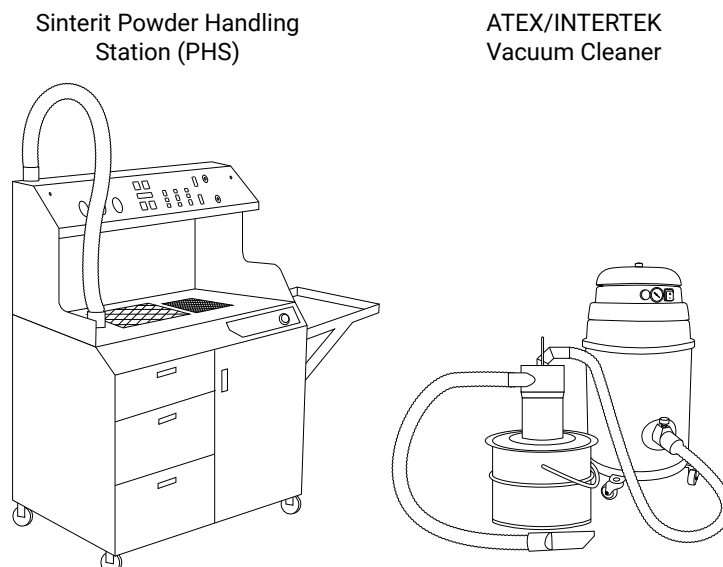

Fig. 9.1 Dedicated Sinterit solutions for cleaning the printer.



4. Collect the remaining in the print chamber powder. You can use the dedicated nozzles that come with the PHS.

	<p>IMPORTANT! Keep the PHS/vacuum hose inlet just above the powder surface.</p>	
--	--	--

5. Do not be concerned if some powder remains around the recoater. Choose **DONE**.
6. Press the arrow buttons to the left and right, in order to collect the dust from under the recoater.
7. Once the print chamber is clean, press **DONE**.

9.2 CLEANING THE OVERFLOW CONTAINER

1. Choose **OPEN FRONT DOOR** and open the printer door.
2. Press **UNLOCK OVERFLOW**, to release the overflow container electrolock.

	<p>IMPORTANT! After 10 seconds the lock will reactivate and it will no longer be possible slide out the drawer with the overflow container. If you still want to slide the overflow container out, press the UNLOCK OVERFLOW button again back on the printer screen.</p>
--	---

3. Open the printer door and slide out the drawer with an overflow container (fig. 9.2).
4. Take the overflow container out of the drawer and transfer its contents into a metal bucket or onto the PHS worktop.
5. Put the overflow container back in its drawer.

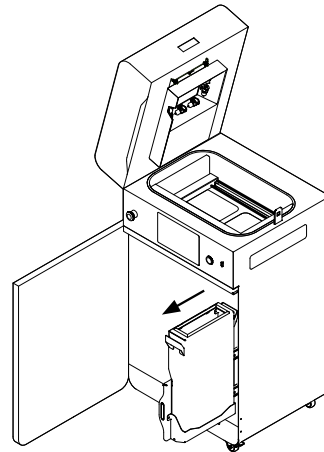

Fig. 9.2 Sliding out the drawer with an overflow container.

	<p>IMPORTANT! Make sure the overflow container is oriented correctly once you put it back. Pay attention to the markings on the container.</p>
--	---

6. Slide the **UNLOCK OVERFLOW** button to the **UNLOCKED** position, to release the electrolock and slide the drawer back into the printer.

	<p>ATTENTION! Attempting to slide the overflow container back into the printer without unlocking the safety mechanism can damage it.</p>
--	---



7. Close the printer door.
8. If you want to learn how to refresh the powder and what exact mix to use, choose **SHOW REFRESH INFO**. If you wish to instead do that another time, choose **LATER**.

10. Printing with PA11

Printing with the PA11 powder requires the use of the inert gas.

	<p>WARNING!</p> <ul style="list-style-type: none">• The built-in oxygen level sensor is not a certified device and its signal must not be taken as the only warning. Store the Lisa X printer and the gas cylinder in a well-ventilated area.• When the alarm signal is activated, open the windows/ventilate the room and leave the room immediately.• If people around the machine experience disturbing symptoms, they should leave the room immediately.	
	<p>WARNING!</p> <ul style="list-style-type: none">• The Lisa X printer with the inert gas installation should only be operated in a well-ventilated space.• Do not inhale the gas.• Danger of unsealing – inert gases displace oxygen from the air. Low enough oxygen concentrations may cause loss of consciousness or even death by asphyxiation.	

1. The inert gas source may safely be connected even if the printer is turned off, the connection is equipped with an electronic safety valve.
2. Make sure that the inert gas pressure remains between 4 and 8 [bar] / 58 to 116 [psi] throughout the whole process. Please note that it may fluctuate if a gas tank and a pressure regulator are in use.

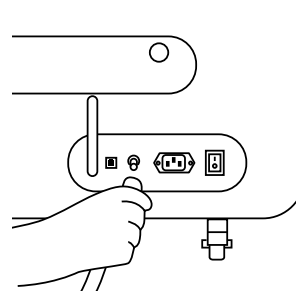

Fig. 10.1 Connecting the inert gas source.

	<p>IMPORTANT!</p> <ul style="list-style-type: none">• The inert gas source may safely be connected even if the printer is turned off, the connection is equipped with an electronic safety valve.• Make sure that the inert gas pressure remains between 4 and 8 [bar] / 58 to 116 [psi] throughout the whole process. Please note that it may fluctuate if a gas tank and a pressure regulator are in use.
--	---



11. Powder refreshment

	<p>IMPORTANT!</p> <ul style="list-style-type: none">• Every SLS powder recovered in the printing process requires sifting.• Not every SLS powder recovered in the printing process requires adding fresh powder.• For detailed information please refer to the specifications of the specific SLS powder. You can find them on our website www.sinterit.com.
	<p>IMPORTANT!</p> <p>Information about how much fresh powder needs to be added in the refresh process will be displayed on the printer screen after the printer cleaning step and also generated in a report from Sinterit Studio.</p>
 	<p>ATTENTION!</p> <p>Always wear appropriate personal protective equipment when working with powder: clothing, goggles, mask, and gloves. You will find a suitable kit in the Dedicated Powder Tools package.</p>

Powder refreshment is a process that restores the initial properties of the powder that is recovered from the printing.

11.1 POWDER REFRESHMENT WITH PHS

	<p>IMPORTANT!</p> <p>If the SLS powder you recovered from the printing process does not require adding fresh powder, skip steps 3-7.</p>
--	---

1. After the PHS has finished sifting the powder, remove the metal container from the PHS sifting module.
2. Insert an empty metal container into the sifting module.
- Adding fresh powder
 3. Prepare an appropriate portion of fresh powder.
 4. Add prepared fresh powder to the sifted powder in the metal container.
 5. Close the metal container with the lid and lock clamping ring.
 6. Shake the metal container with the powder for at least 15 seconds to mix the powders.
 7. Wait a moment for the powder in the metal container to settle. Open the metal container.
8. Place the powder funnel (from Dedicated Powder Tools) over the metal container and lock the clamping ring.
9. Pour the mixed powder onto the PHS worktop above the powder chamber.
10. Press the **DEPOWDERING** button on the PHS control panel.
11. Make sure the HOSE A is connected to the vacuum cleaner.
12. Press the **DEPOWDERING** button again on the PHS control panel.
13. **CHECK POWDER CONTAINER** starts flashing. Open the door and make sure that the metal container is in its place and it is empty.
14. Close the PHS door.
15. Wait until all the powder is removed from the powder chamber.



16. Hold down the DEPOWDERING button for 3 seconds to start the powder sifting process.
17. The timer will start counting down 25 min. After this time, the powder sifting will be finished.
18. Repeat steps 1-2, 8-17 three times to make sure the powder is thoroughly mixed and sifted.
19. The received powder is ready to use. Remember to store the powder in a tightly closed metal container.

11.2 POWDER REFRESHMENT WITH POWDER SIEVE OR METAL STRAINER



IMPORTANT!

If the SLS powder you recovered from the printing process does not require adding fresh powder, skip steps 2-6.

1. Sift the unsintered powder that remains after the printing process. Use the Powder Sieve or the metal strainer included in the Dedicated Powder Tools.
 2. Prepare an appropriate portion of fresh powder.
 3. Add prepared fresh powder to the sifted powder in the metal container.
 4. Close the metal container with the lid and lock clamping ring.
 5. Shake the metal container with the powder for at least 15 seconds to mix the powders.
 6. Wait a moment for the powder in the metal container to settle. Open the metal container.
7. Place the powder funnel (from Dedicated Powder Tools) over the metal container and lock the clamping ring.
8. Carefully pour the prepared powder onto a removable metal sieve (part of the Sieve) or sift through a metal strainer.
9. Make sure there is an empty metal container inside the Sieve.
10. Close the Sieve lid and turn on the unit.
11. Wait until all the powder is sifted.
12. Remove the metal container with the sifted powder from the Sieve.
13. Repeat steps 1, 7-12 three times to make sure the powder is thoroughly mixed and sifted.
14. The received powder is ready to use. Remember to store the powder in a tightly closed metal container.

Adding
fresh powder



12. Basic maintenance

To determine if it is time to service the printer components, from the Main Menu, select **MAINTENANCE** and then select **COMPONENT MAINTENANCE**. In case the printer components need to be replaced or maintained, this information will also be displayed on the screen while the machine is being prepared for printing.

	<p>ATTENTION! Maintenance must always be performed by qualified technicians who are trained in the tasks they perform.</p>
	<p>ATTENTION! Remember to perform regular machine maintenance. Exceeding the time indicated by the counters can have a negative effect on the quality of printouts and even cause damage to the machine.</p>
	<p>ATTENTION! Before performing any maintenance:</p> <ul style="list-style-type: none">• make sure you have carefully read the directions in this manual and know how the printer works,• make sure that no unauthorized people are in the work area,• make sure the necessary tools are available and that they are in a good condition,• make sure there is sufficient lighting, and if necessary, provide portable 24-volt lamps. <p>Use of unsuitable tools or tools in poor condition can cause serious damage.</p>
	<p>ATTENTION! Before performing any maintenance work, always wear appropriate protective clothing, goggles, face mask and/or gloves appropriate to the type of work being performed.</p>
	<p>IMPORTANT! If you have any questions, please contact our After-sales team. For more information, please visit our website www.sinterit.com under the support section.</p>



12.1 CLEANING THE PYROMETER WINDOW

1. Choose **UNLOCK LID** on the printer screen.
2. Push on the lid and pull it up using the lid handle.



IMPORTANT!

After 10 seconds the electrolock will reactivate and it will no longer be possible to lift the lid. If you still want to open the printer, slide the **UNLOCK LID** button again on the printer screen.

3. Delicately wipe the pyrometer window with a cotton cloth soaked in 2% salicylic spirit (ethanol solution) or another ethanol-based cleaning solution. You may also use cleaning wipes provided in Dedicated Powder Tools.
4. Wipe the pyrometer window again with a dry cotton cloth, in order to remove any alcohol residue.



IMPORTANT!

Do not use isopropyl alcohol to clean the pyrometer window.

12.2 CLEANING THE LASER PROTECTIVE GLASS



ATTENTION!

If the laser protective glass is damaged (visible scratches, cracks), replace it with a new one.



ATTENTION!

It is necessary to clean the laser protective glass immediately after each printing of rubber-like materials.



ATTENTION!

Beware of sharp edges.



STOP!

- Be careful not to damage the heating module.
- Do not clean the laser protective glass under running water.
- Do not clean the laser protective glass above the print chamber
- Note any remaining lint on the surface of the glass after cleaning.

1. Choose **UNLOCK LID** on the printer screen.
2. Push on the lid and pull it up using the lid handle.



IMPORTANT!

Po 10 sekundach uruchomi się elektrozamek i nie będzie możliwe otwarcie kłapy drukarki. Jeśli nadal chcesz otworzyć klapę drukarki, przesuń ponownie przycisk **UNLOCK LID** na ekranie drukarki.

3. Remove the split pin from the heating module.
4. Lower the heating module.



5. Unscrew two quick release nuts.
6. Take the laser protective glass out.
7. Delicately wipe the glass on both sides with a cotton cloth soaked in 2% salicylic spirit (ethanol solution) or another ethanol-based cleaning solution. You may also use cleaning wipes provided in Dedicated Powder Tools.



IMPORTANT!

Do not use isopropyl alcohol to clean the laser protective glass.



IMPORTANT!

Cleaning the laser protective glass after printing from rubber-like materials requires the use of agents containing isobutanol and methyl ethyl ketone, xylene and toluene.

8. Wipe the glass again on both sides with a dry cotton cloth.
9. Slide the metal tabs of the laser protective glass into the mounting brackets below the laser module.
10. Lock the laser protective glass in place by mounting and tightening the two quick release nuts.
11. Lift the heating module.
12. Reinsert the heating module safety pin.

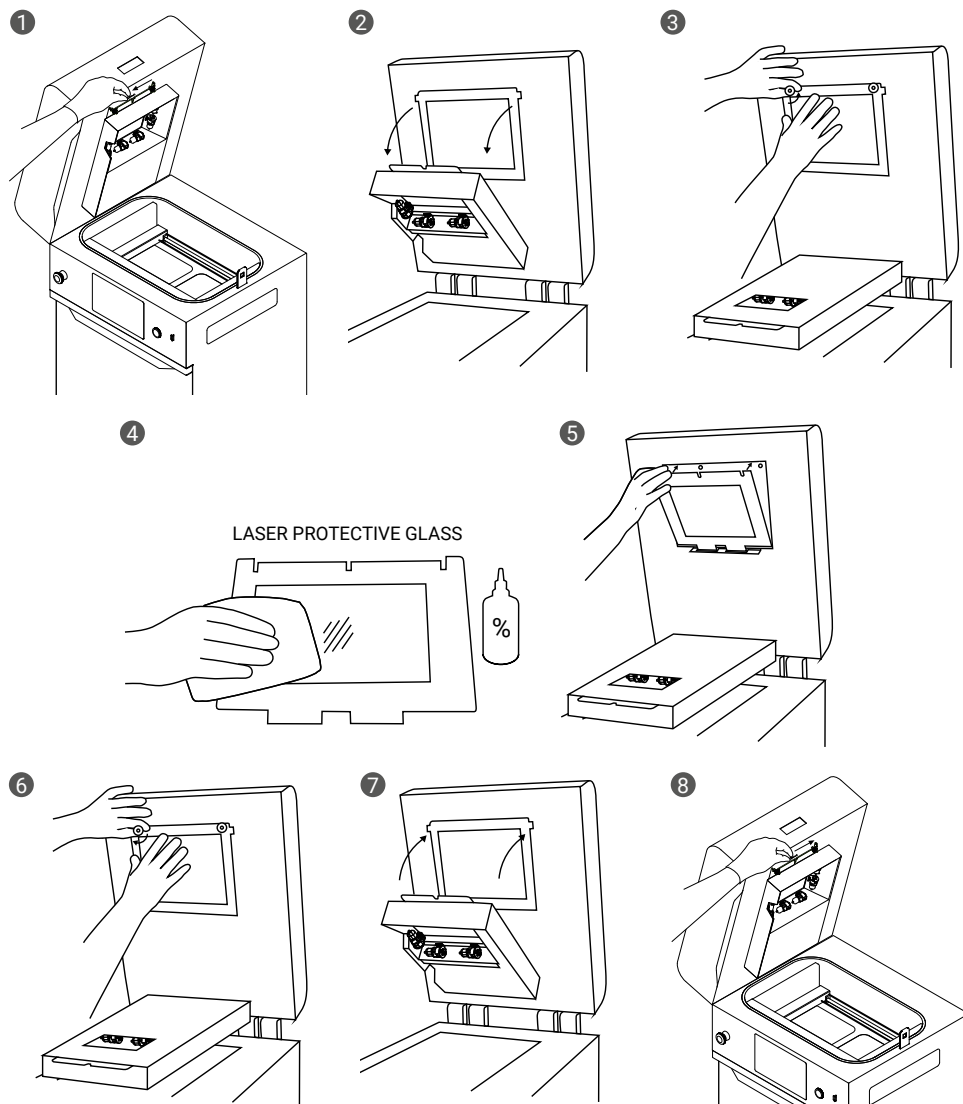





Fig. 12.1 Cleaning the laser protective glass.



12.3 CLEANING THE AREA UNDER THE PRINT CHAMBER

During printing, powder may accumulate in the area under the print chamber. A thin, even layer of powder is no cause for concern. It indicates correct sealing and regular operation of the machine. Powder accumulating in only one place indicates a problem with the sealing of the Beds. For more information, please visit our website www.sinterit.com under the support section.

	<p>WARNING! Before cleaning the space under the print chamber, turn the printer off at the power switch and unplug the power cable. Risk of electric shock.</p>
	<p>CAUTION!</p> <ul style="list-style-type: none">• Beware of moving parts. Risk of crushing hands.• Pay attention to the markings on the machine.
	<p>ATTENTION! When cleaning, be careful not to damage the Print Bed and Feed Bed mechanisms.</p>

1. Choose **OPEN THE DOOR** on the printer screen.
2. Open the printer door.
3. Turn the printer off at the power switch and unplug the power cable.
4. Carefully remove the powder from the area under the print chamber. You can use the ATEX Vacuum Cleaner to do this.
5. Close the printer door.

13. Technical support

If you have any questions or doubts, please contact our after-sales department.

e-mail: support@sinterit.com

phone: +48 570 702 886

For a list of distributors and technical support in each country, please visit our website www.sinterit.com

14. Packing the machine for shipping

14.1 PREPARING THE PRINTER

1. From the main menu, select **CLEAN THE PRINTER** and follow the directions. For a more detailed description, see Chapter 9. *Cleaning the printer*.
2. Remove the split pin and lower the heating module.
3. Unscrew two quick release nuts.
4. Take the laser protective glass out and put it in its original box.
5. Secure the laser module with the protective plastic cover that was removed during the first startup of the printer.
6. Lift the heating module and secure it with a split pin.
7. Insert the box with the laser protective glass into the print chamber.
8. Close the printer lid.
9. Disconnect the power cable from the printer.



14.2 PACKING THE PRINTER INTO THE FLIGHT CASE

1. Unlock the latches on the case door (4 pcs.). Lift the lock handle up to a perpendicular position, then turn it clockwise.
2. Take the flight case cover off.
3. Lift the gangway support and lower the gangway.
4. Slide the printer into the flight case. This step requires the help of another person.



ATTENTION!

Start packing the printer from the lid hinges side.

5. Attach the power cable to the flight case cover.
6. Fold the gangway and attach the flight case cover.
7. Lock the flight case lid latches.
8. Secure the flight case with foil and tape.

15. Legal notice

Where this manual refers to Sinterit or the Company, this means Sinterit sp. z o.o. with its legal seat in Krakow, registered by the District Court for Kraków-Śródmieście in Krakow, XI Commercial Division of the National Court Register under number: 535095, NIP (tax number): 6793106416, with the share capital for a date of publication of this manual of PLN 102,200 (say: one hundred and two thousand two hundred).

This document contains material protected under copyright and industrial property laws. This means that the document may not be, including but not limited to, reproduced or modified without the consent of Sinterit.

This manual serves to assist in the correct use of the device, perform basic maintenance and, if necessary, to solve simple problems, allowing to maintain the device in a good condition.

This manual contains content exclusively for the provision of information and the use by individuals professionally trained and engaged in the operation and maintenance of the equipment described below.

The information contained in this document is intended for use only with the product made by Sinterit and called Sinterit Lisa X printer.

Due to the constant development of Sinterit's products the information contained in this manual, specifications and markings are subject to change without notice.

16. Disclaimer

Sinterit is not responsible for any use of this information in relation to other products.

Although every effort has been taken to provide accurate information about the product, Sinterit assumes no responsibility for any incorrect information or omission. Sinterit reserves the right to correct any errors and disclaims any liability in situations resulting from these errors.

Sinterit shall not be liable for defects in the printer's firmware.

Further limitations or exclusions of Sinterit's liability may result from the applicable laws or agreements entered into with the buyer of the products.



17. Trademarks

Sinterit logo is a registered trademark of the Company.

18. Warranty information

The terms of the warranty are set forth in the agreement between the buyer and the Company.

In case of a purchase made in the Sinterit online shop, the terms of the guarantee are specified in the Terms and Conditions, subject to the acceptance of the Customer before placing an order.

In case of purchases made outside the Sinterit online store, the warranty terms may be specified in the offer, or in another form chosen by the Company to provide the customer with relevant information before making a purchase decision.

Unless otherwise stated in the documents referred above or specifically agreed, the Sinterit's warranty does not cover, including but not limited to:

- damages, abnormalities or malfunction caused by a client or any third party;
- damages, abnormalities or malfunction caused by inappropriate use, effects of force, insufficient or inappropriate maintenance, abnormal operating conditions, incorrect installation or inadequate servicing;
- damages, abnormalities or malfunction caused by dismantling, alterations, tuning or other changes of the product by a client or any third party made without the written consent of Sinterit;
- damages, abnormalities or malfunction caused by or related to use of consumables other than those being supplied by Sinterit;
- damages, abnormalities or malfunction caused by or related to use of product against its intended use, instructions/manuals or safety regulations;
- damages, abnormalities or malfunctions Sinterit is not liable for, according to the applicable law,
- damages exceeding the price paid by the client;
- normal wear and tear, including but not limited to replaceable Short Infrared heaters, Laser Protection Glass, Recoater cord, Recoater slide shaft, Recoater bearing system;
- damages, abnormalities or malfunction caused by the incompatibility of client software and Sinterit software or for any malware, or for non-fitness of software for a particular purpose;
- costs incurred by the client in connection with the conclusion of the product sale agreement as well as storage or insurance of products;
- damages of property caused by the defect of the product;
- loss of profits;
- incidental, indirect, special, consequential or punitive damages.

The warranty does not cover any cleaning of working parts.

The abovementioned exclusions of warranty apply as well to any other liability of Sinterit, to the widest extent permitted by the applicable law.

Terms of liability of sellers other than Sinterit such as distributors or resellers shall be regulated by them in separate documents.

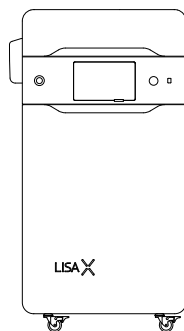
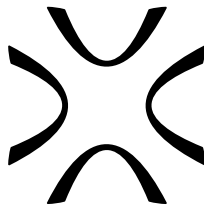

SINTERIT Sp. z o.o.
ul. Nad Drwina 10 bud. B3, 30-741 Krakow, Poland
www.sinterit.com
Contact: +48 570 967 854